

# RIDDER TK25V

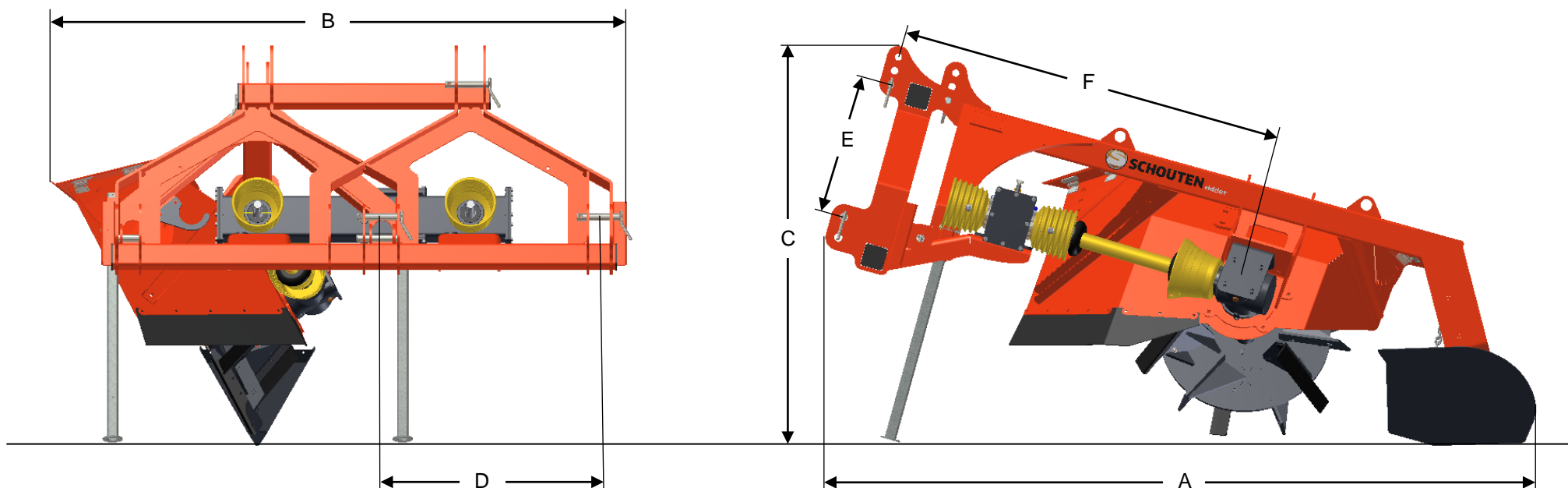

## DIMENSIONS

A	LENGTH	2500 MM	E	DISTANCE LIFT PIN – LINK PIN (CHAIN)	493/568 MM
B	WIDTH	2030 MM			543/618 MM
C	HEIGHT	1355 MM			593/668 MM
D	HITCH WIDTH	790 MM	F	DISTANCE LIFT PIN – CUTTING WHEEL	1540 MM

# RIDDER TK25V

## MACHINE INFORMATION

TYPE	TK25V
WEIGHT	485 KG
HITCH TYPE	CAT II
PTO SPEED	540 RPM
PTO SHEAR BOLT PROTECTION	1.860 NM
POWER REQUIREMENT	30-40 HP
SPREADING WIDTH	+/- 10 M
DRIVING SPEED	0-2 KM/H

## SKID SHOE

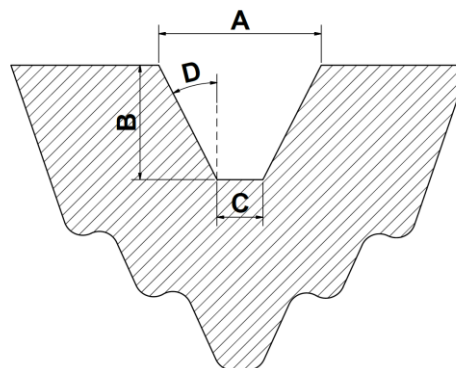

	FW0	FW8
A	255 MM	335 MM
B	250 MM	250 MM
C	0 MM	80 MM
D	27°	27°

## CUTTING WHEEL

TYPE	FW0	FW8
NUMBER OF KNIVES (L+R)	3+3	3+3
NUMBER OF REAMERS (L+R)	3+3	3+3
DIAMETER	795 MM	795 MM
ROTATIONAL SPEED	15.3 M/S	15.3 M/S

