

# RIDDER TK25V

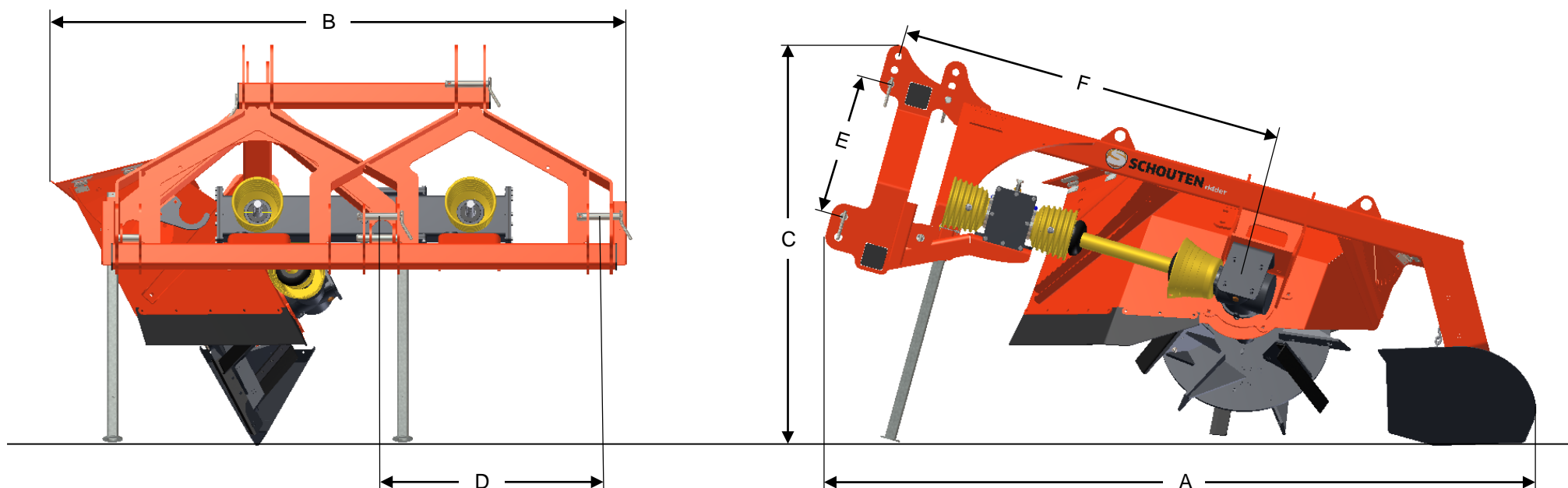

## AFMETINGEN

A	LENGTE	2500 MM
B	BREEDTE	2030 MM
C	HOOGTE	1355 MM
D	AFSTAND TUSSEN HEFARMEN	790 MM

E	AFSTAND HEFPEN - TOPKETTINGPEN	493/568 MM
		543/618 MM
		593/668 MM
F	AFSTAND HEFPEN - FREESWIEL	1540 MM

# RIDDER TK25V

## MACHINEINFORMATIE

TYPE	TK25V
GEWICHT	485 KG
AANSPANNING	CAT II
TOERENTAL PTO	540 RPM
PTO BREEKBOUT BEVEILIGING	1860 NM
BENODIGD VERMOGEN	30-40 PK
SPREIDBREEDTE	+/- 10 MTR
RIJSNELHEID	0-2 KM/H

## SLEEPVOET

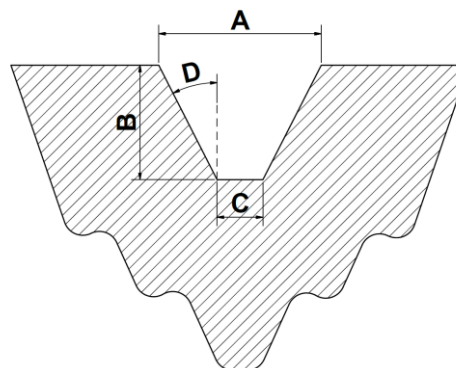

	FW0	FW8
A	255 MM	335 MM
B	250 MM	250 MM
C	0 MM	80 MM
D	27°	27°

## FREESWIEL

TYPE	FW0	FW8
AANTAL MESSEN (L+R)	3+3	3+3
AANTAL RUIMERS (L+R)	3+3	3+3
DIAMETER	795 MM	795 MM
OMTREKSNELHEID	15.3 M/S	15.3 M/S

