

RIDDER TK45

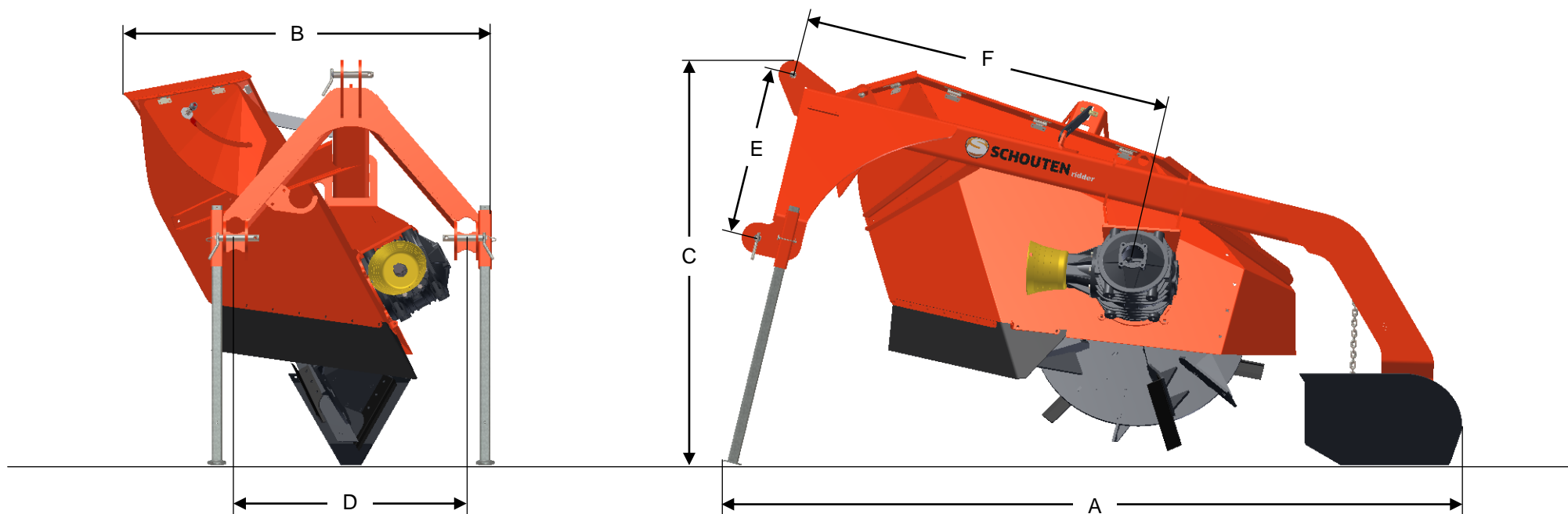

DIMENSIONS

A	LENGTH	2800 MM	E	DISTANCE LIFT PIN – LINK PIN (CHAIN)	636 MM
B	WIDTH	1400 MM	F	DISTANCE LIFT PIN – CUTTING WHEEL	1485 MM
C	HEIGHT	1542 MM			
D	HITCH WIDTH	880 MM			

RIDDER TK45

MACHINE INFORMATION

TYPE	TK45
WEIGHT	545 KG
HITCH TYPE	CAT II
PTO SPEED	540 RPM
PTO SHEAR BOLT PROTECTION	2.920 NM
POWER REQUIREMENT	60-80 HP
SPREADING WIDTH	+/- 15 M
DRIVING SPEED	0-3 KM/H

SKID SHOE

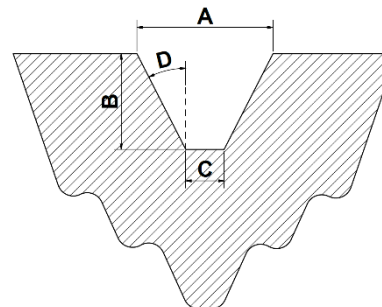

	FW8	FW12
A	435 MM	475 MM
B	350 MM	350 MM
C	80 MM	120 MM
D	27°	27°

CUTTING WHEEL

TYPE	FW8	FW12
NUMBER OF KNIVES (L+R)	3+3	3+3
NUMBER OF REAMERS (L+R)	3+3	3+3
DIAMETER	1000 MM	1000 MM
ROTATIONAL SPEED	17.7 M/S	17.7 M/S

