

RIDDER TK45

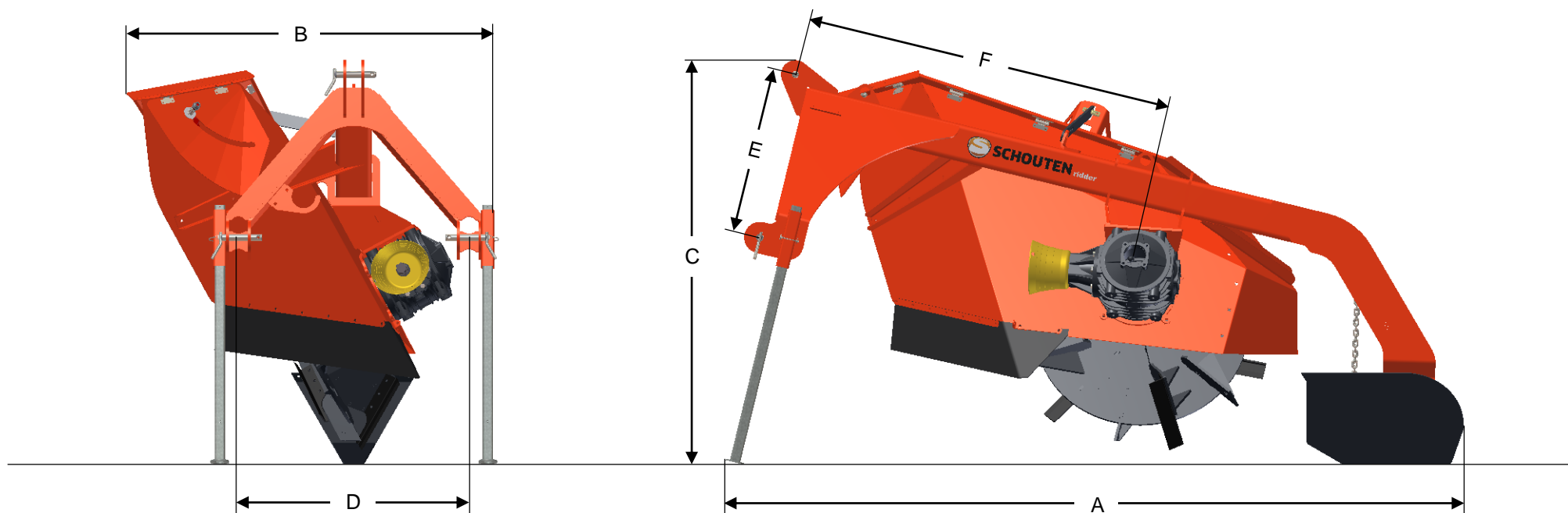

AFMETINGEN

A	LENGTE	2800 MM	E	AFSTAND HEFPEN - TOPKETINGPEN	636 MM
B	BREEDTE	1400 MM	F	AFSTAND HEFPEN - FREESWIEL	1485 MM
C	HOOGTE	1542 MM			
D	AFSTAND TUSSEN HEFARMEN	880 MM			

RIDDER TK45

MACHINE INFORMATIE

TYPE	TK45
GEWICHT	545 KG
AANSPANNING	CAT II
TOERENTAL PTO	540 RPM
PTO BREEKBOUT BEVEILIGING	2920 NM
BENODIGD VERMOGEN	60-80 PK
SPREIDBREEDTE	+/- 15 MTR
RIJSNELHEID	0-3 KM/H

SLEEPVOET

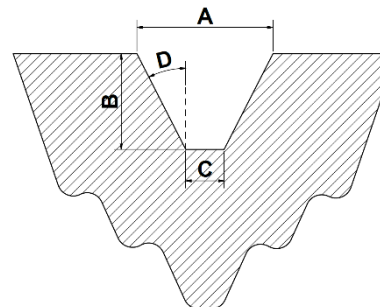

	FW8	FW12
A	435 MM	475 MM
B	350 MM	350 MM
C	80 MM	120 MM
D	27°	27°

FREESWIEL

TYPE	FW8	FW12
AANTAL MESSEN (L+R)	3+3	3+3
AANTAL RUIMERS (L+R)	3+3	3+3
DIAMETER	1000 MM	1000 MM
OMTREKSNELHEID	17.7 M/S	17.7 M/S

