

# GIGANT G400-15

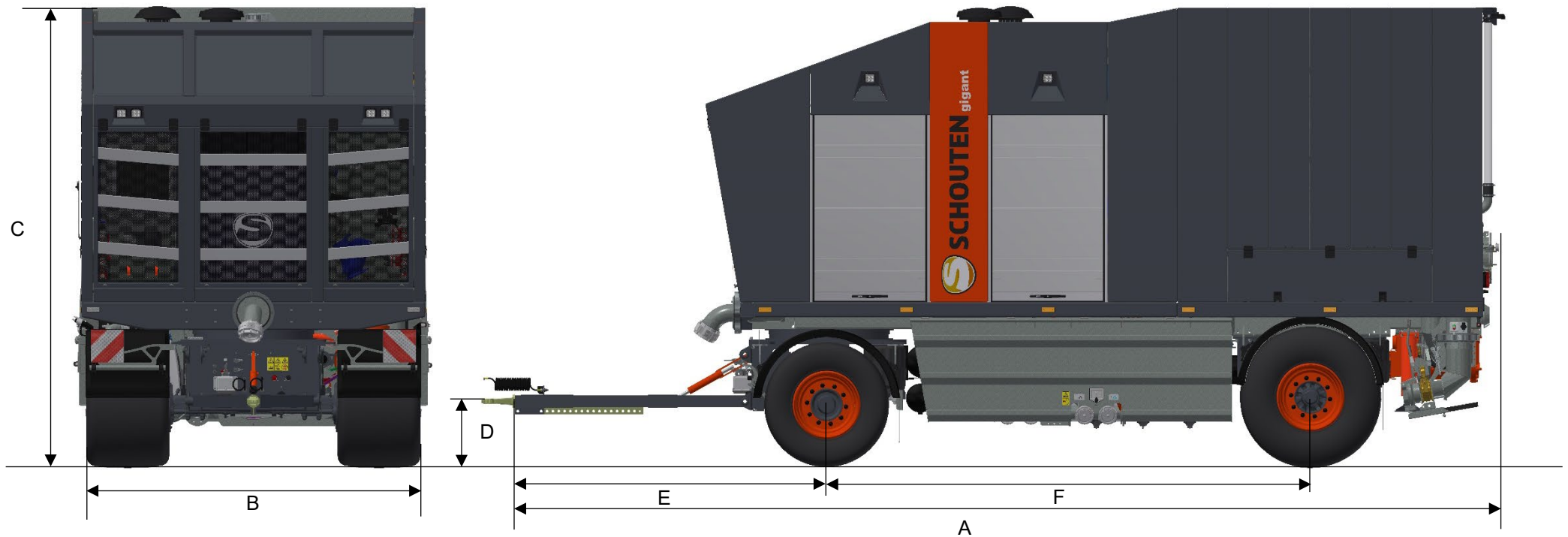

## DIMENSIONS

A	LENGTH	8630 MM	E	TOWING EYE – FRONT AXLE	3000 MM
B	WIDTH	2950 MM	F	WHEELBASE	4150 MM
C	HEIGHT	3880 MM	G		
D	HITCH HEIGHT	440 MM	H		

# GIGANT G400-15

## MACHINE INFORMATION

TYPE	G400-15
WEIGHT	16.000 KG
CHASSIS	BPW AIRSUSPENSION
FRONT AXLE	HYDR. DRIVEN
SLURRYCONTAINER	15 M <sup>3</sup>
WATERCONTAINER	OPTION 6 M <sup>3</sup>
MOTOR	SCANIA 385 PK
DRIVE SLURRYPUMP	POWERBAND
DRIVE COMPRESSOR	POWERBAND

HYDR. CIRCUIT	1X OPEN CENTER 200 BAR
	1X CLOSED CENTER 400 BAR
SLURRYPUMP	DODA AFI45/CORNELL 4NHTB
CAPACITY SLURRYPUMP	400 M <sup>3</sup> /UUR
COMPRESSOR	SCREW/OIL LUBRICATED
CAPACITY COMPRESSOR	25 M <sup>3</sup> /MIN
SUCTION PUMP	VOGELSANG 8600 L/MIN
DRIVE SUCTION PUMP	HYDR. STEPLESS

## OPTIONS



TOOLFRAME FOR QUAD AND WATERPUMP

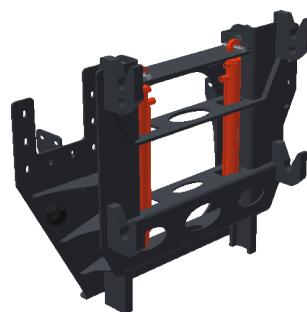

HITCH FOR TOOLFRAME



HOSEREELER