

# GIGANT G400-15

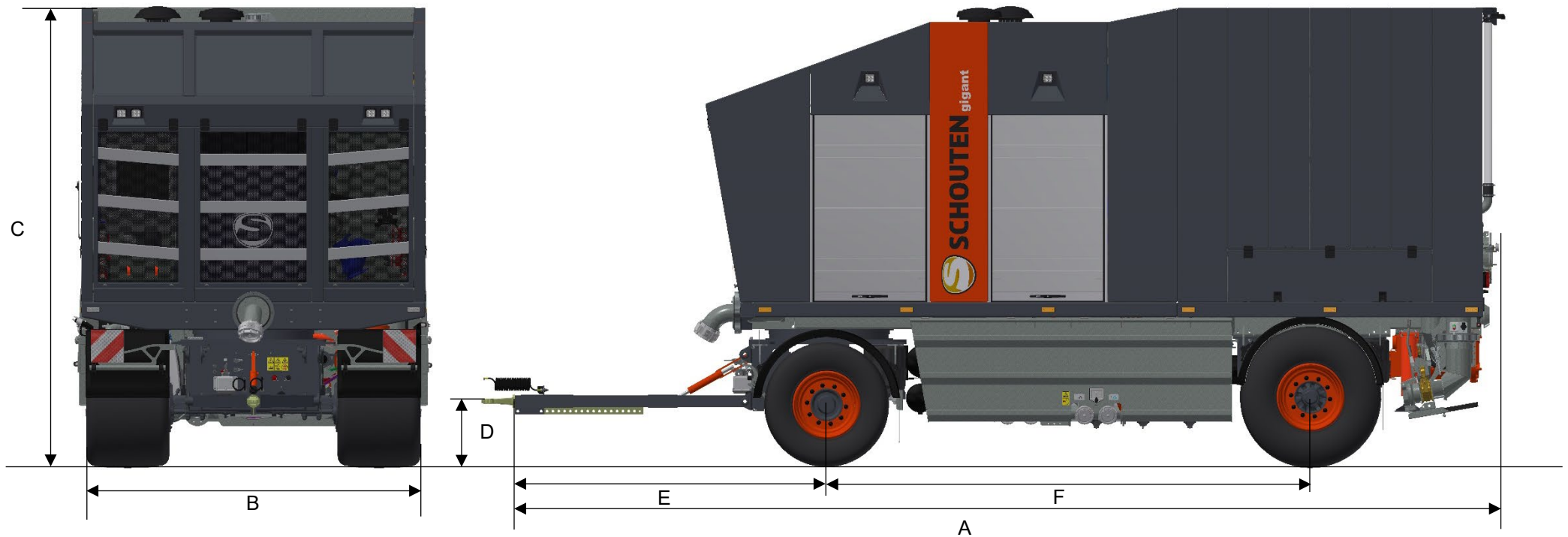

## AFMETINGEN

A	LENGTE	8630 MM	E	TREKOOG – HART VOORAS	3000 MM
B	BREEDTE	2950 MM	F	WIELBASIS	4150 MM
C	HOOGTE	3880 MM	G		
D	AANSPANHOOGTE	440 MM	H		

# GIGANT G400-15

## MACHINE INFORMATIE

TYPE	G400-15
GEWICHT	16.000 KG
ONDERSTEL	BPW LUCHTGEVEERD
VOORAS	HYDR. AANGEDREVEN
MESTCONTAINER	15 M <sup>3</sup>
WATERCONTAINER	OPTIE 6 M <sup>3</sup>
MOTOR	SCANIA 385 PK
AANDRIJVING MESTPOMP	POWERBAND
AANDRIJVING COMPRESSOR	POWERBAND

HYDRAULISCH CIRCUIT	1X OPEN CENTER 200 BAR
	1X CLOSED CENTER 400 BAR
MESTPOMP	DODA AFI45/CORNELL 4NHTB
CAPACITEIT MESTPOMP	400 M <sup>3</sup> /UUR
COMPRESSOR	SCHROEF/OLIEGESMEERD
CAPACITEIT COMPRESSOR	25 M <sup>3</sup> /MIN
AANZUIGPOMP	VOGELSANG 8600 L/MIN
AANDRIJVING AANZUIGPOMP	HYDRAULISCH TRAPLOOS

## OPTIES



ACHTERFRAME MET AANZUIGING

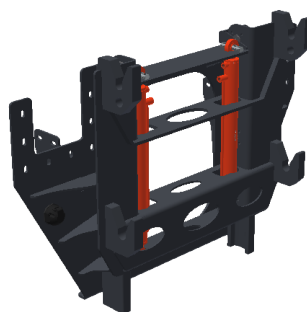

HEFINRICHTING



WATERSLANGHASPEL