

ORCAN PU100T

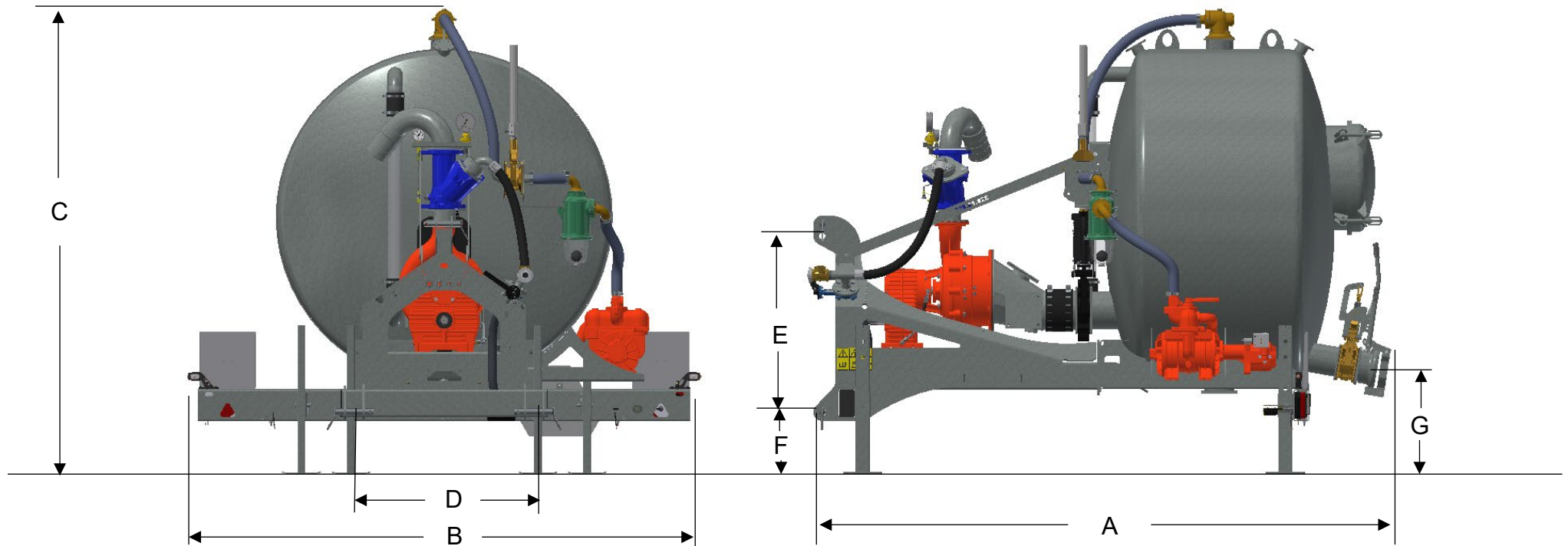

AFMETINGEN

A	LENGTE	2932 MM	E	HEFKOGEL - TOPSTANGKOGEL	895/955 MM
B	BREEDTE	2500 MM	F	AANSPANHOOGTE	314 MM
C	HOOGTE	2366 MM	G	HOOGTE AANKOPPELING	530 MM
D	AANSPANBREEDTE	915 MM			

ORCAN PU100T

MACHINE INFORMATIE

TYPE	PU100T
GEWICHT	1.800 KG
CENTRIFUGAAL MESTPOMP	DODA AFI 35HD
CAPACITEIT MESTPOMP	5.000 L/MIN
AANDRIJVING MESTPOMP	PTO 1.000 RPM
PTO BREEKBOUTBEVEILIGING	2.920 NM

VACUUMPOMP	B&P MEC3000H
CAPACITEIT VACUUMPOMP	3.600 L/MIN
AANDRIJVING VACUUMPOMP	HYDRAULISCH
PERSLUCHTAANSLUITING	STORZ NA 52
BALKEERKLEP	DN100/PN16
TANKINHOUD	1,75 M ³

OPTIES



WATERAANSLUITING INCL. METER