

# ORCAN PU100Z

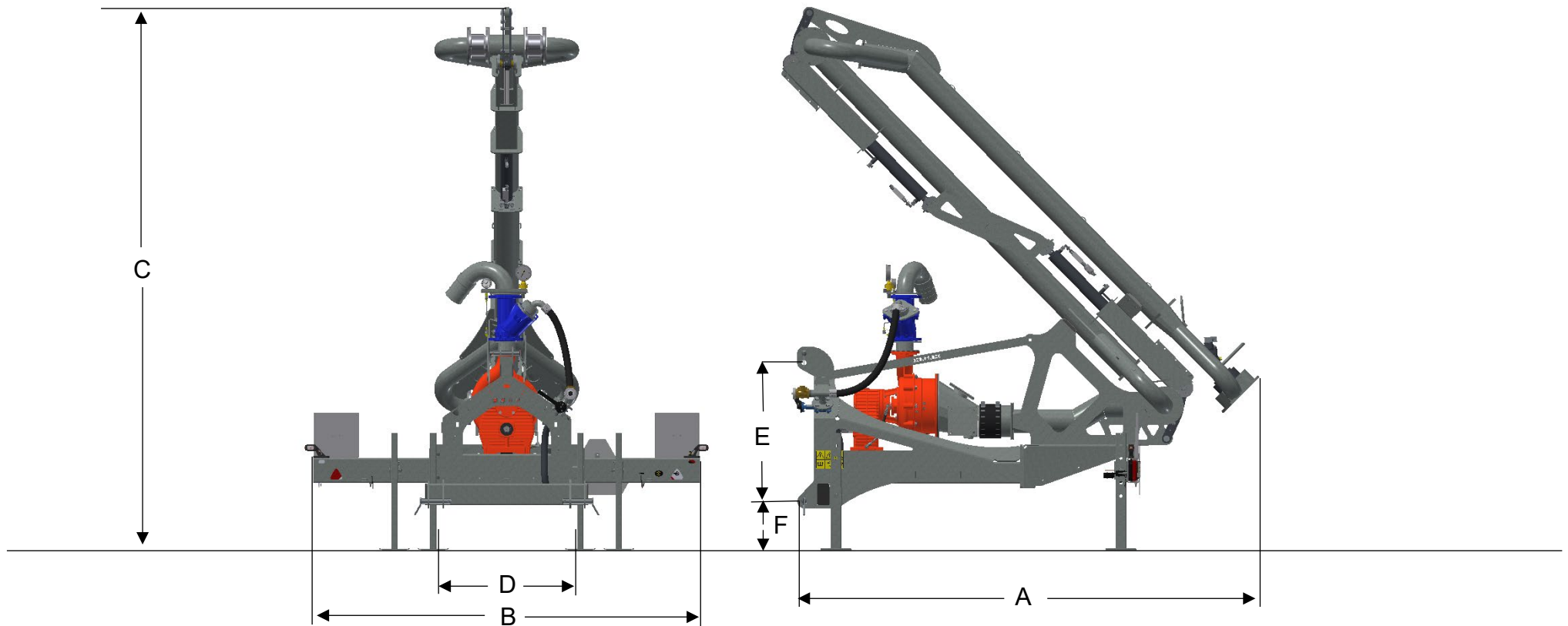

## AFMETINGEN

A	LENGTE	3085 MM	E	HEFKOGEL - TOPSTANGKOGEL	895/955 MM
B	BREEDTE	2500 MM	F	AANSPANHOOGTE	314 MM
C	HOOGTE	3507 MM			
D	AANSPANBREEDTE	915 MM			

# ORCAN PU100Z

## MACHINE INFORMATIE

TYPE	PU100Z
GEWICHT	1.260 KG
CENTRIFUGAAL MESTPOMP	DODA AFI 35HD
CAPACITEIT MESTPOMP	5.000 L/MIN
AANDRIJVING MESTPOMP	PTO 1.000 RPM
PTO BREEKBOUTBEVEILIGING	2.920 NM
VULPOMP	MÄKI REINI 3S
CAPACITEIT	12.000 L/MIN
AANDRIJVING	HYDRAULISCH – 0-160 LTR/MIN
OPVOER HOOGTE	25 MTR
PERSLUCHTAANSLUITING	STORZ NA 52
BALKEERKLEP	DN100/PN16

## OPTIES



WATERAANSLUITING INCL. METER

