

PHOENIX PX1802

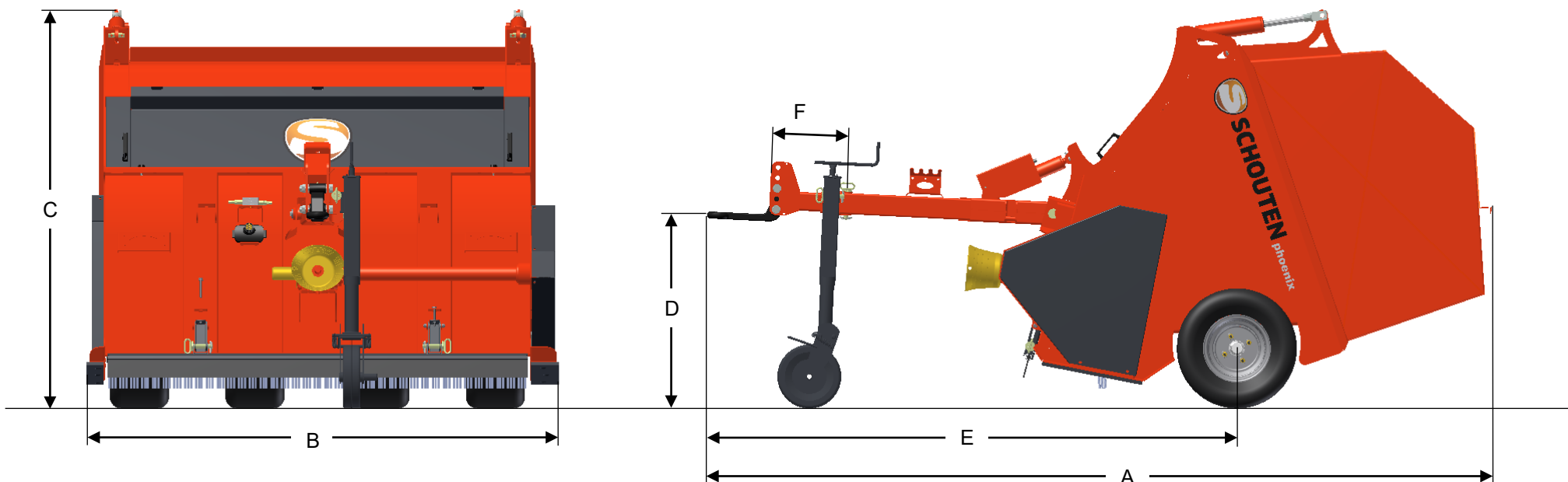

DIMENSIONS

A	LENGTH	3310 MM	E	DISTANCE HITCH – AXLE	2344 MM
B	WIDTH	2070 MM	F	DRAWBAR EXTENDABLE	2X 125 MM
C	HEIGHT	1750 MM			
D	HITCH HEIGHT	710-980 MM			

PHOENIX PX1802

MACHINE INFORMATION

TYPE	PX1802
WEIGHT	960 KG
HITCH TYPE	TOP HITCH
BIN CAPACITY	2.2 M ³
REQUIRED HYDRAULIC VALVES	2X DOUBLE-ACTING
AXLE	2X SWINGING AXLE
CARRYING CAPACITY	2.160 KG
TIRES	20X10.00-10 6PR
DRIVE SWEEPING UNIT	PTO-V-BELTS
PTO SPEED	540 RPM
POWER REQUIREMENT	20 PK
WORKING WIDTH	180 CM
DIAMETER SWEEP ROTOR	Ø 385 MM
NUMBER OF BRUSHES	4 PIECES
SPEED SWEEP ROTOR	600 RPM
DIAMETER TRANSPORT ROTOR	Ø 386 MM
NUMBER OF TRANSPORTATION RUBBERS	4 PIECES
SPEED TRANSPORT ROTOR	1.080 RPM

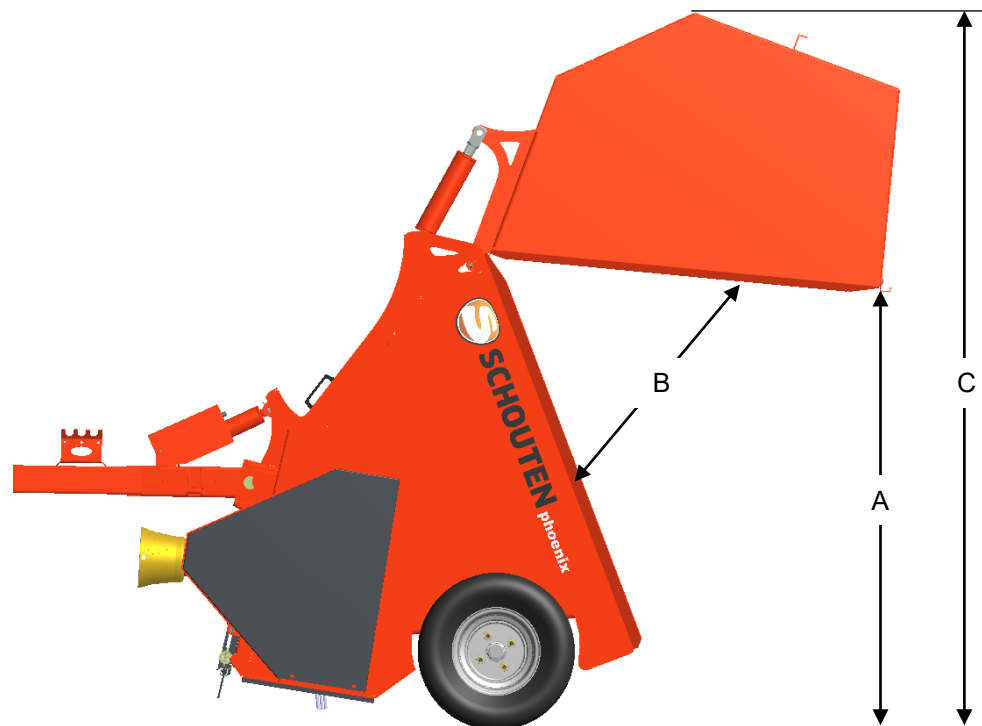

DIMENSIONS MAX. TILTING POSITION

A MAX. EMPTYING HEIGHT	1352 MM
B BIN EMPTYING ANGLE	64°
C TOTAL HEIGHT	2300 MM