

# RABBIT R1825

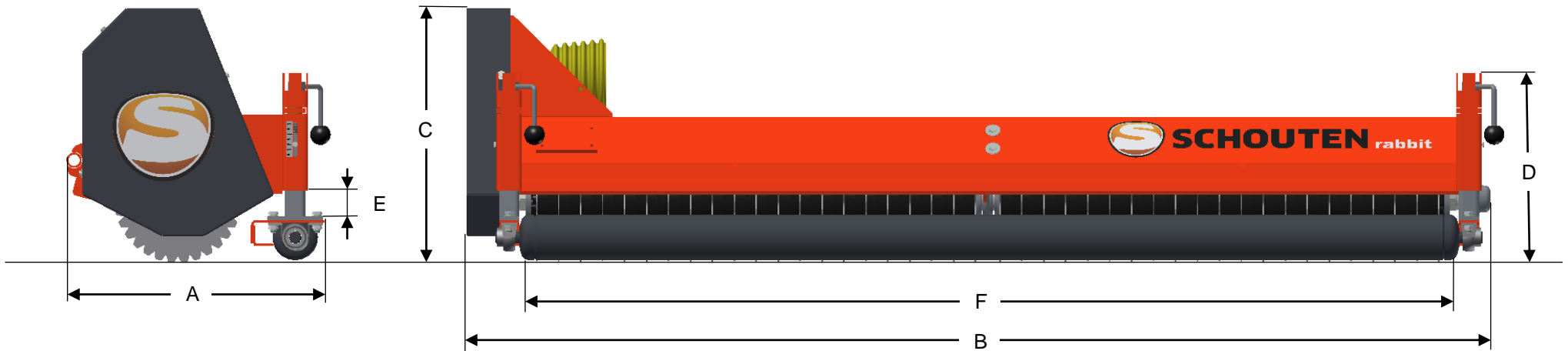

## DIMENSIONS

A	LENGTH	506 MM	E	ADJUSTMENT RANGE ROLLER	50 MM
B	WIDTH	2008 MM	F	WORKING WIDTH	1800 MM
C	HEIGHT DRIVE SIDE	497 MM			
D	HEIGHT	289 MM			

# RABBIT R1825

## MACHINE INFORMATION

TYPE	R1825
WEIGHT	160 KG
WORKING WIDTH	180 CM
MAX. WORKING DEPTH	15 MM
DRIVE	PTO – CHAIN
PTO SPEED	540RPM
POWER REQUIREMENT	20 HP
PTO PROTECTION	RATCHET CLUTCH
MAX. TORQUE RATCHET CLUTCH	500 NM
DIAMETER AERATING KNIFE	Ø 250 MM
NUMBER OF AERATING KNIVES	42 PIECES
DISTANCE BETWEEN AERATING KNIVES	40 MM
SPEED AERATING AXLE	500 RPM
ROTATION DIRECTION AERATING AXLE	CUT MILLING
ROLLER ADJUSTMENT	STEPLESS TO 50MM
DIAMETER ROLLER	Ø 90 MM

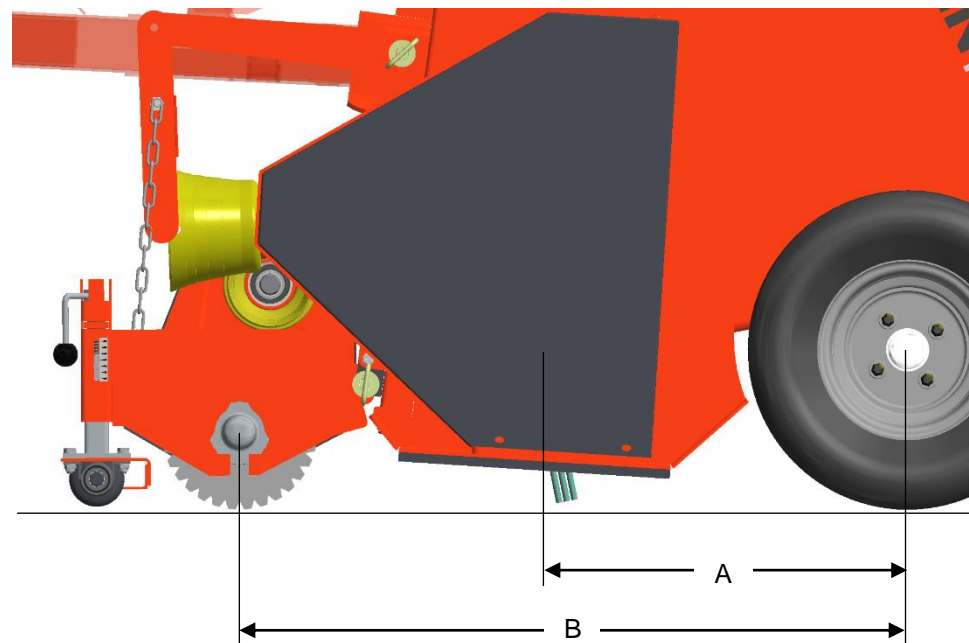

## BUILD ON DIMENSIONS PX1802

A	DISTANCE AXLE – SWEEP ROTOR	588 MM
B	DISTANCE AXLE – AERATING AXLE	1082 MM