

RABBIT RD2345

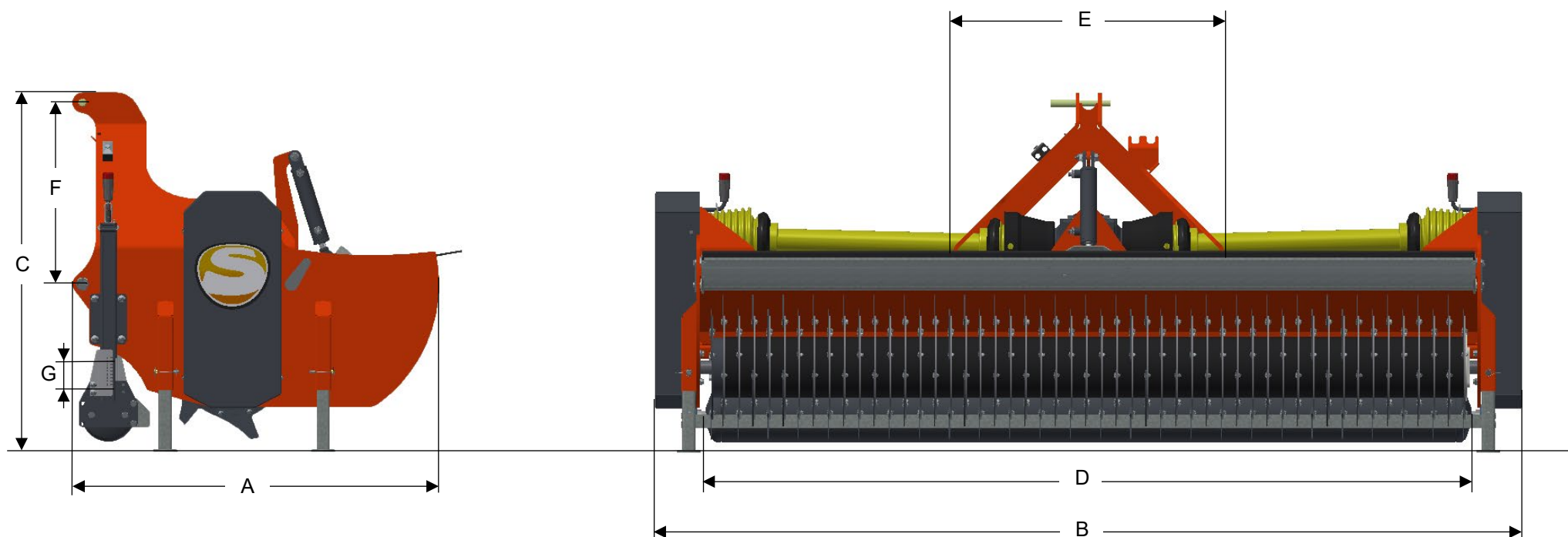

DIMENSIONS

| | | | | | |
|---|---------------|---------|---|------------------------------|------------|
| A | LENGTH | 1250 MM | E | HITCH WIDTH | 680-880 MM |
| B | WIDTH | 2580 MM | F | DISTANCE LIFT PIN – LINK PIN | 536 MM |
| C | HEIGHT | 1020 MM | G | ADJUSTMENT RANGE ROLLER | 50 MM |
| D | WORKING WIDTH | 2250 MM | | | |

RABBIT RD2345

MACHINE INFORMATION

| | | | |
|--------------------|---------------|-------------------------------|---------------------|
| TYPE | RD2345 | TYPE OF SCARIFYING KNIFE | 3-PARTS STAR-KNIVES |
| WEIGHT | 700 KG | DIAMETER KNIFE | Ø 450 MM |
| HITCH TYPE | CAT 1 + 2 | NUMBER OF KNIVES | 153 PIECES |
| WORKING WIDTH | 2295 MM | DISTANCE BETWEEN KNIVES | 42 MM |
| MAX. WORKING DEPTH | 50 MM | ROTATION SPEED KNIFE AXLE | 540/1000 RPM |
| DRIVE | PTO – V-BELTS | ROTATION DIRECTION KNIFE AXLE | CLIMB MILLING |
| PTO SPEED | 540/1000 RPM | ROLLER ADJUSTMENT | STEPLESS TO 50MM |
| POWER REQUIREMENT | 70 HP | DIAMETER ROLLER | Ø 160 MM |
| | | SLIDE ADJUSTMENT | HYDRAULIC |

OPTIONS



CUTTING KNIVES