

QUICKFEED MDW180

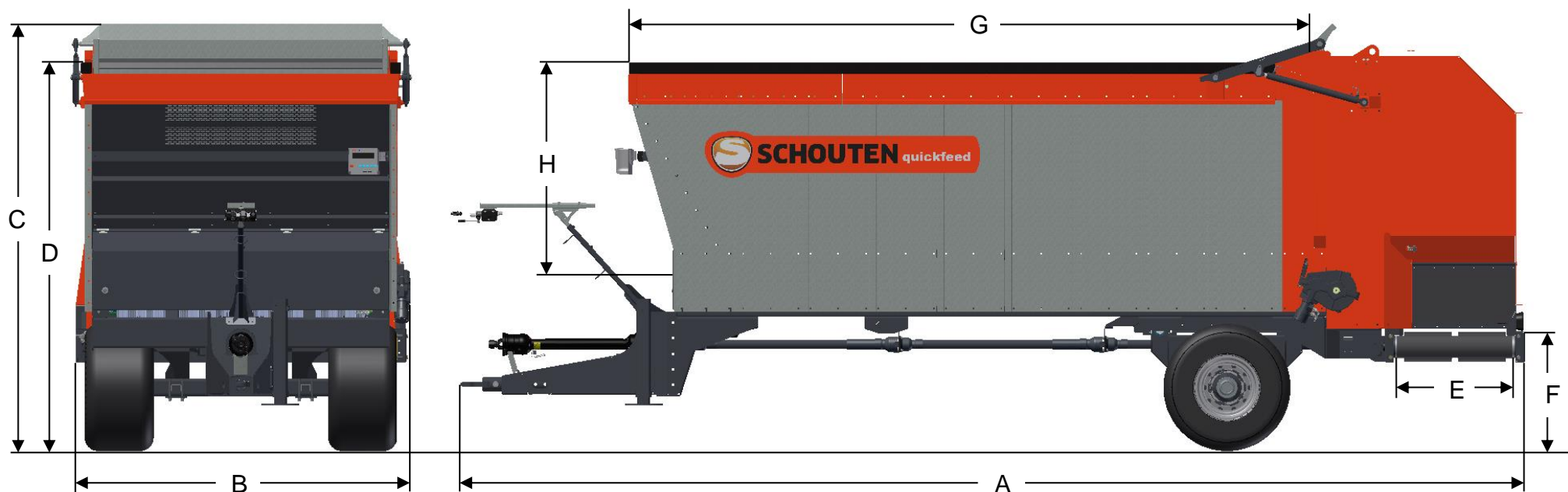

DIMENSIONS

A	LENGTH	7860 MM	E	WIDTH CONVEYOR BELT	850 MM
B	WIDTH	2472 MM	F	HEIGHT CONVEYOR BELT	854 MM
C	HEIGHT	3155 MM	G	BIN LENGTH	5085 MM
D	LOADING HEIGHT	2870 MM	H	BIN HEIGHT	1615 MM

QUICKFEED MDW180

MACHINE INFORMATION

TYPE	MDW180	NUMBER OF AUGERS	4X VERTICAL
WEIGHT	4750 KG	AUGERS DRIVE	PTO/GEARBOX
BIN CAPACITY	18 M ³	PTO SPEED	540 RPM
LOAD CAPACITY SINGLE AXLE	14.000 KG	PTO CAMSHAFT SECURITY	2920 NM
TRACKSIZE AXLE	1800 MM	NUMBER OF FLOORCHAINS	1X 30 TONS
STANDARD TIRES	500/50-17	FLOORCHAIN DRIVE	HYDR
SUPPORT LEG	HYDR. DA	FLOORCHAIN SPEED	0-6 M/MIN
PLASTIC PROTECTION BEAM	80X80 MM	DIRVE CONVEYOR BELT	HYDR
HYDR. POWER REQUIREMENT	40LTR/160BAR	SPEED CONVEYOR BELT	0-6.25 M/SEC

OPTION



WEIGHTSYSTEM



24 TONS PARABOLIC SPRING SUSPENSION

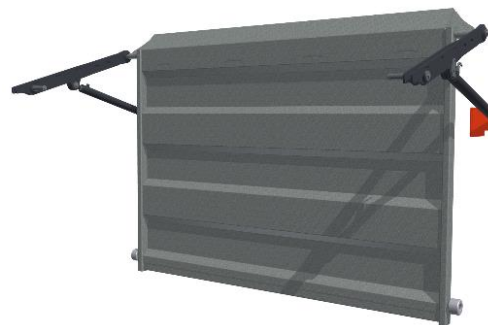

HYDR. PROTECTION DOOR



LIGHTNING